

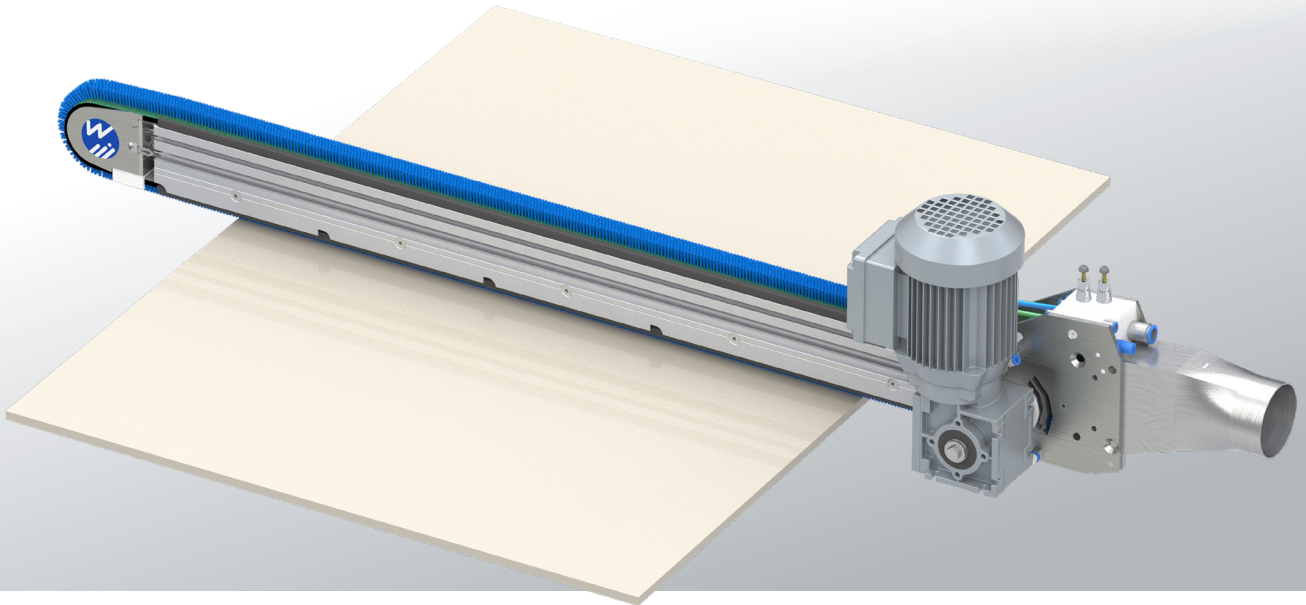

Sword Brush BIX 51..



Brief description

The Sword Brush BIX 51.. is ideal to clean flat surfaces such as furniture and plastic boards or metal blanks as well as guide rollers or conveyor belts. The brush filaments are micro-moistened with a patented antistatic cleaning agent (Ingromat®) thus providing an effective removal of even very fine dust particles. A pressure buffer is included in the machine. It provides for a constant wiping pressure of the linear brushes onto even slightly uneven surfaces.

Technical details

- 1 x Sword Brush BIX 51/1M/A with pressure buffer and Ingromat® system, required component:
Ingromat® regulator and filter unit IR 100.. (standard)
resp. control cabinet for pneumatic and electrical functions (option)

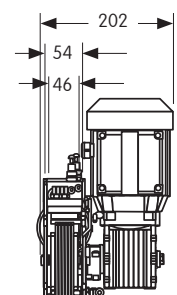
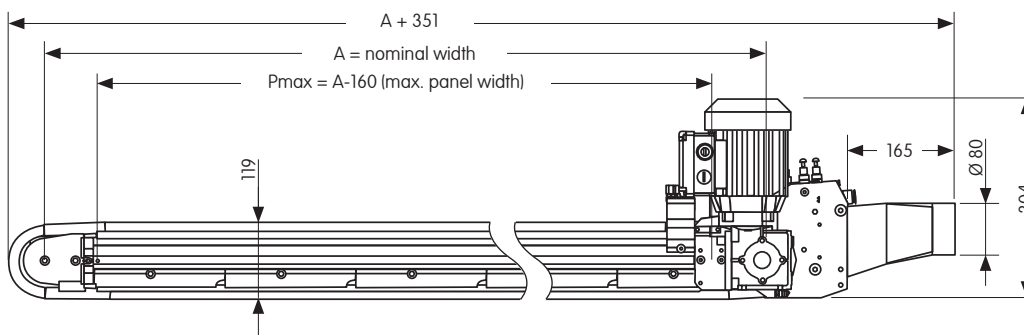

Values in mm

Ordering example

The panel that needs to be cleaned has a max. width of $P_{max} = 800$ mm.

Minimum nominal width of Sword Brush:

$$A_{min} = P_{max} + 160 \text{ mm} = 960 \text{ mm.}$$

The most suitable Sword Brush has a nominal width of $A = 1000$ mm.

Order code [2280-007](#)

describes BIX 51/1M/1000

Options for special applications



2293-

BIK 51..
without
pressure
buffer



2294-

BRX 51..
without
Ingromat®



2295-

BRK 51..
without
pressure buffer
and without
Ingromat®

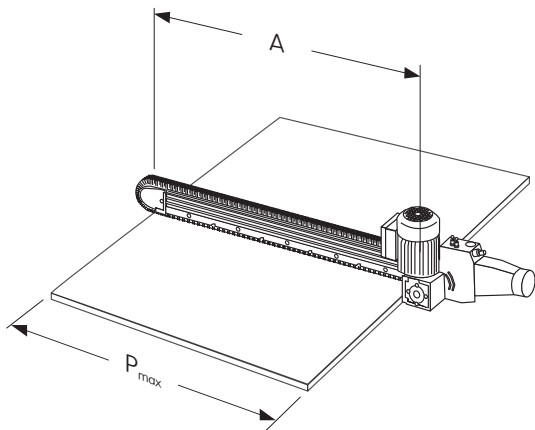

Order code

BIX 51..



2280 -

	Nominal width A mm	Nominal width A inch	
- 003	400	15.75	
- 004	520	20.47	
- 005	650	25.59	
- 058	700	27.56	
- 006	850	33.46	
- 045	900	35.43	
- 007	1000	39.37	
- 008	1100	43.31	
- 031	1200	47.24	
- 009	1300	51.18	
- 030	1400	55.11	
- 010	1500	59.06	
- 011	1650	64.96	
- 059	1700	66.93	
- 012	1750	68.89	
- 032	1900	74.80	
- 013	2000	78.74	
- 033	2100	82.68	
- 014	2200	86.61	
- 056	2300	90.55	
- 015	2500	98.43	
- 050	2700	106.29	
- 016	2750	108.26	
- 060	2800	110.23	
- 036	2900	114.17	
- 017	3000	118.11	
- 037	3100	122.05	
- 018	3200	125.98	
- 039	3400	133.85	
- 019	3500	137.79	
- 020	3750	147.64	
- 021	4000	157.48	
- 022	4300	169.29	
- 023	4500	177.17	

with profile reinforcement

Explanation

- A Nominal width of Sword Brush
= distance between axes of deviation roller
- P_{max} max. panel width =
A - 160 mm (BIX 51.. / BRX 51..)
A - 80 mm (BIK 51.. / BRK 51..)

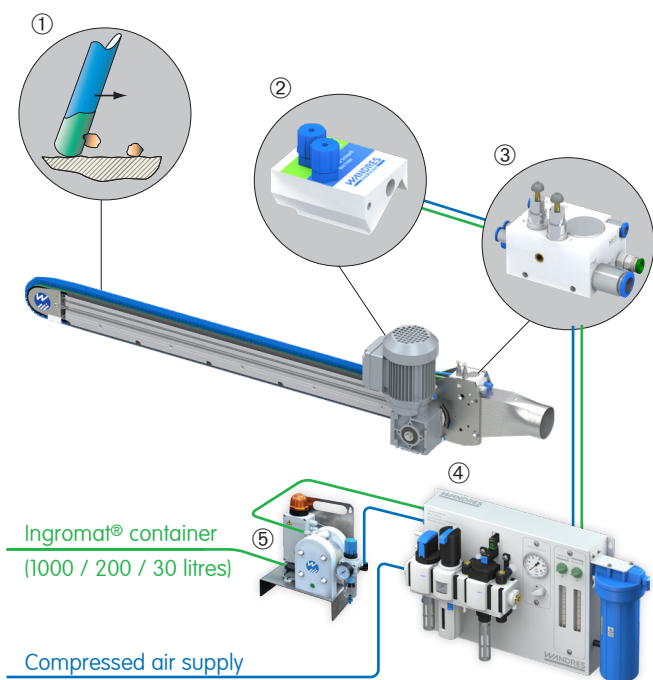

Ingromat® system

Ingromat® is an antistatic cleaning agent. The brush filaments are micro-moistened with Ingromat® thus providing an effective removal of even very fine dust particles

- ① Micro-moistened brush filament with Ingromat® (shown in green)
- ② Ingromat® sprayer SQL 51..
- ③ Distributor block VTB 100..
- ④ Ingromat® regulator and filter unit IR 100..
Ingromat® filter, dosage and display of inner pressure of pressure buffer
- ⑤ Option: Ingromat® central supply pump, e.g. IS 102 (Self priming pneumatic double membrane pump with filter regulator and air control valve (oil free).)

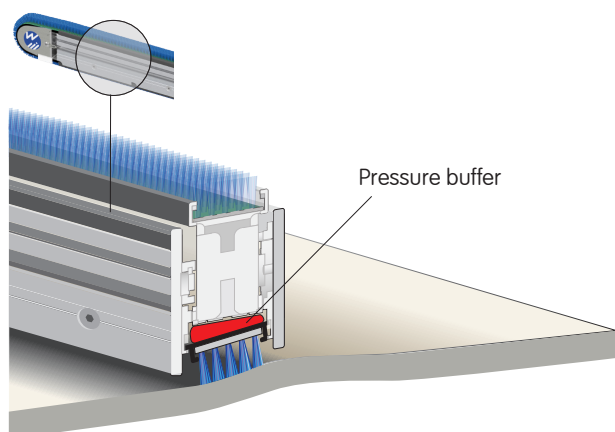

Pressure buffer

The linear brush is mounted on a pressure buffer that provides flexibility and compensates irregularities and thickness variations of up to +/- 2 mm. Thus brush filaments are not excessively bent, they will remain in a vertical position. This provides a constituent wiping pressure and a premium cleaning quality.

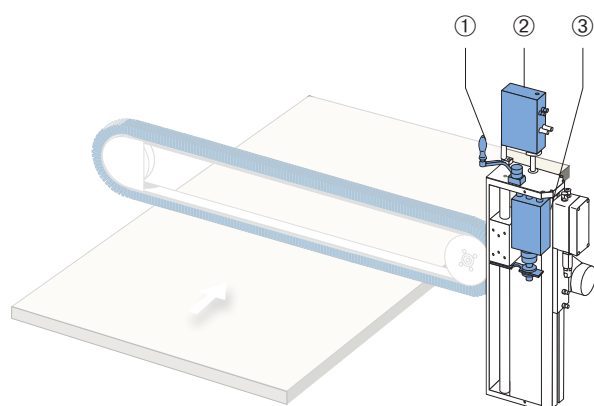

Option: Height adjustment

The cleaning module may be mounted on an adjustment frame to integrate a height adjustment:

- ① Manual adjustment via crank (HVM)
- ② Electrical adjustment via actuator (HVE). An automatic thickness adjustment is possible if HVE is linked to the overall control
- ③ Pneumatic adjustment via pneumatic cylinder (HVP). Quick removal of module from material surface, e.g. in crash situations. The mechanical and the electrical height adjustment may be combined with the pneumatic adjustment.

Technical details



Electrical details

Drive Sword Brush	1 x 0.25 kW SEW motor, IP 54, UL-compatible 50 Hz; Δ 220 - 240 V; 1.14 A; Y 380 - 415 V; 0.66 A 60 Hz; Δ 240 - 266 V; 1.03 A; Y 415 - 480 V; 0.6 A
Main valve	2/2 directional valve: 1 x 24 V DC; 1.5 W

Pneumatic details

Compressed air quality	filtered (max. particle size < 40 μ m), oil free (residual oil < 1.5 mg/m ³ at 24°C)
Compressed air connection	1 x 1/2" female thread; 6 bar
Compressed air consumption	230 l/min (with standard self-cleaning nozzle) 280 l/min (with reinforced self-cleaning nozzle)

Details regarding antistatic liquid

Ingromat® hose connection	1 x \varnothing 8 mm
Ingromat® consumption	0.2 - 0.8 l/h

Suction requirements

Suction connection	1 x \varnothing 80 mm
Suction capacity	1 x 9 m ³ /min
Operating parameters	min. -500 Pa vacuum; min. 28 m/s (measured at suction connection)

Acoustic emission

Sound pressure level LpA	approx. 74 dB(A) Acoustic emission depends on the surface structure and the geometry of the subject material.
--------------------------	--

Linear brush

Type of linear brush	Quadro R6
Filament material	Polyamid 6.12
Filament length	17 mm
Filament diameter \varnothing	0.127 mm

Transport speed

Max. transport speed	100 m/min
----------------------	-----------

Dimensions of subject panel

Min. panel length	$L_{\min} = 240$ mm
Min. panel width	$P_{\min} = 60$ mm
Max. panel width	$P_{\max} = A - 160$ mm (BIX 51.. / BRX 51..) A - 80 mm (BIK 51.. / BRK 51..)

Technical information is subject to changes.

Germany
Wandres GmbH micro-cleaning
Im Gewerbepark 8
79252 Stegen
Tel. +49 (0)7661-9330-0
sales@wandres.com
www.wandres.com

USA
Wandres Corporation
719 W. Ellsworth Rd., Suite 7
USA-Ann Arbor, MI 48108
Tel. +1-734-214-9903
sales@wandresusa.com

China
万喆清洁设备（上海）有限公司
Wandres Cleaning Machinery (Shanghai) Co., Ltd.
755B, Tower 3, No. 88 Keyuan Road
Pudong, Shanghai, China 201203
Tel. + 8621 68520069
china@wandres.com

WANDRES
micro-cleaning